

# Users Manual

## ARMADILLO 6XV



The Model and Serial Numbers of your machine are shown on the nameplate mounted on the machine. This information is needed when contacting Technical Support or ordering parts. For your convenience, use the space below to record the Model and Serial Numbers of your machine and the date it was placed into service.

**MODEL NUMBER:** \_\_\_\_\_

**SERIAL NUMBER:** \_\_\_\_\_

**DATE PLACED INTO SERVICE:** \_\_\_\_\_

All information contained in this manual is current at the time of printing. However, due to constant updates and improvements, we reserve the right to make changes at any time without notice.

**© Copyright 2000, Minuteman PowerBoss, Inc.**

All rights reserved. This manual may not be copied or reproduced in any form, without the written permission of Minuteman PowerBoss, Inc.

# PowerBoss®

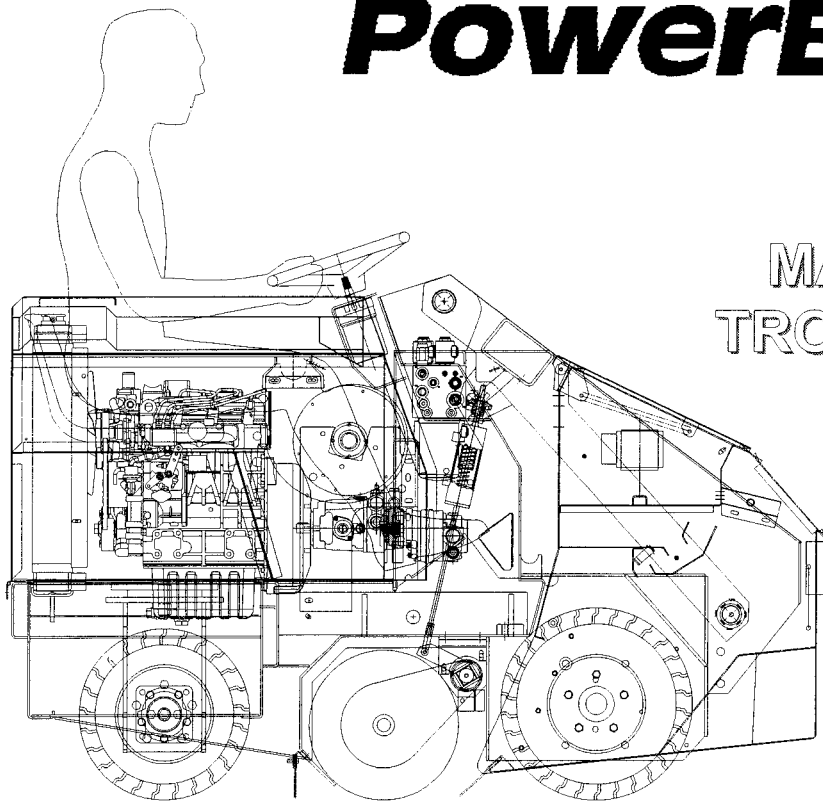

## OPERATION, MAINTENANCE & TROUBLESHOOTING **SW/6XV**

### TABLE OF CONTENTS

Features .....	7
Warranty .....	8
<b>SAFETY</b>	
Safety Symbols .....	9
Safety Decals .....	10
Basic PowerBoss® Safety .....	12
<b>OPERATION</b>	
<b>Operating Procedures</b>	
Pre-Operation Check .....	16
Starting .....	16
Slowing and Stopping .....	16
Operating on Grades .....	17
Sweeping .....	17
Emptying the Hopper .....	17
Using the Rotary Trash Relocator (RTR™) .....	18
Transporting the Machine .....	19

# SW/6XV

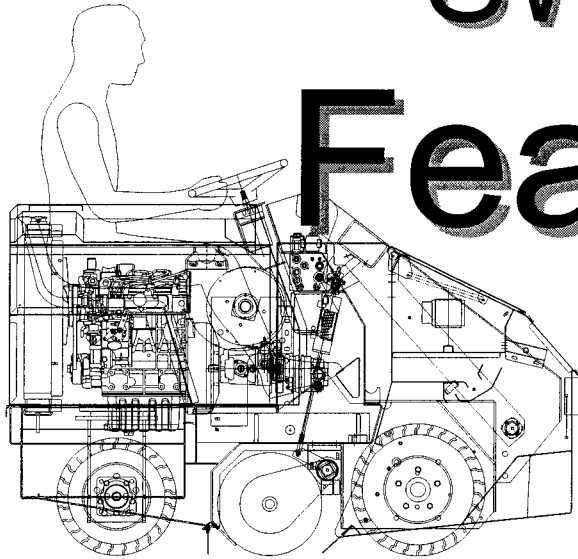

# Features

1. Dust Control Filter: 92S q. Ft. (8.56 m<sup>2</sup>)
2. Electric Filter Shakers
3. Exhaust Air Expelled Rear Engine Compartment
4. Industrial Liquid-Cooled Engine
5. Tri-Phase Air Cleaner
6. Heavy Gauge Unitized Steel Frame Will Stand Up to Abusive Environments
7. Convenient, Operator-Friendly Controls
8. Quick Change Main Broom Floats to Maintain Contact Over Uneven Surfaces
9. Oversized Hopper with RTR™
10. Retractable Quick-Change Side Broom
11. Multi-Level Hopper Dumping
12. Built-In Dust PreFiltering
13. Dust Control On/Off Switch
14. Instant Forward & Reverse Using One Pedal
15. Excellent Maneuverability Due to Compact Size & Rear Wheel Steering
16. 53 Inch Sweep Path Covers Up To 124,080 Square Feet Per Hour
17. 10 Cubic Foot High Dump Hopper Holds Up To 650 Pounds of Debris
18. Gas, LP and Diesel Models Feature Hydraulically Driven Vacuum Fan, Brooms, Rear Drive Tire, Hopper Dump and Power Steering for Reliable Operation
19. Premium-Quality components Reduce Downtime and Cut Maintenance Costs

# **SW/6XV**

## **(LIMITED) PRODUCT WARRANTY**

Minuteman PowerBoss, Inc. (hereafter known as PowerBoss) warrants that the PowerBoss SW/6XV will be free from defects in material and workmanship for a period of 24 months or 1,200 operating hours from date of installation, whichever comes first. Written notice of any claimed defect must be given to PowerBoss within the warranty period and within thirty (30) days after such defect is discovered. Liability under this warranty is limited to either replacing or repairing, at PowerBoss's election, any part or parts deemed defective after examination by PowerBoss or an Authorized Service Representative. The PowerBoss machine or any of its parts returned by customer to PowerBoss or an Authorized Service Representative via prepaid transportation and which is found to be defective, will be repaired or replaced and returned to customer via prepaid surface transportation within the Continental US. On the other hand, should a part be found not defective, inspection and handling charges may be charged to the customer by PowerBoss or an Authorized Service Representative.

For one hundred eighty (180) days from date of installation, PowerBoss will provide repair labor, at no charge, solely through an Authorized Service Representative. Thereafter, labor will be charged.

This warranty does not extend to the PowerBoss machine, or its parts, that have been subject to misuse, accident or improper handling, installation, maintenance or application, nor does it extend to PowerBoss machine and/or parts which have been repaired or altered outside PowerBoss's plant or the facility of Authorized Service Representative.

This warranty does not apply to routine wearable parts of the PowerBoss machine such as brushes, flaps, filters, seals, point, plugs, hoses or similar items. Moreover, this warranty does not extend to the PowerBoss machine or part replaced or repaired under this warranty.

Only replacement parts supplied by PowerBoss are warranted for 30 days after installation.

The warranty for optional engines shall be limited to the warranty extended to PowerBoss by the supplier.

THE WARRANTY SET FORTH HEREIN IS IN LIEU OF AND EXCLUDES ANY AND ALL OTHER WARRANTIES, EXPRESS OR IMPLIED, ARISING BY OPERATION OF LAW OR OTHERWISE, INCLUDING, BUT NOT LIMITED TO, ANY IMPLIED WARRANTY OF MERCHANTABILITY OR FITNESS FOR A PARTICULAR PURPOSE, AND CUSTOMER WAIVES ANY OBLIGATION OR LIABILITY OR POWERBOSS ARISING IN TORT OR STRICT LIABILITY IN TORT, OR FOR LOSS OR USE, REVENUE OR PROFIT WITH RESPECT TO POWERBOSS MACHINE AND/OR PARTS FOR ANY LIABILITY OF CUSTOMER TO ANY THIRD PARTY, OR FOR OTHER DIRECT, INCIDENTAL OR CONSEQUENTIAL DAMAGES.

# SAFETY SYMBOLS



**WARNING:** To warn of hazards or unsafe practices which could result in severe personal injury or death.



**CAUTION:** To warn of hazards or unsafe practices which could result in equipment or property damage and minor personal injury.

# SAFETY DECALS

Decals directly attached to various parts of the sweeper are highly visible safety reminders which should be read and observed. Make sure the decals are replaced if they become illegible or damaged. The decal below is located in the drive compartment. Other safety decals on your machine appear on the next page.



## CAUTION

**For Your Safety And Safety Of Others:**

- 1. DO NOT Operate Machine:  
Unless Operation Manual Is Read And Understood.  
Unless Authorized And Trained.  
In Areas With Flammable Or Explosive Conditions.  
Without Adequate Ventilation.**
- 2. Do Not Use Flammable Cleaning Materials.**
- 3. Inspect Vehicle For Fuel Leakage.**
- 4. Drive Slowly On Inclines And Slippery Surfaces.**
- 5. Do Not Power Dump Hopper Unless Vehicle Is On A  
Level Surface.**
- 6. Before Leaving Vehicle: Lock Parking Brake, Stop  
Engine, And Remove Key.**

Part Number 301854

# SAFETY DECALS (Continued)

Located at the Impeller:

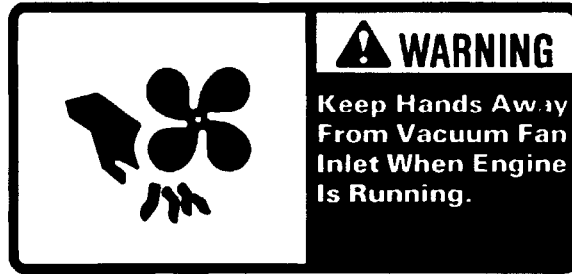

Part Number 301729

Located on the High Dump Hopper:

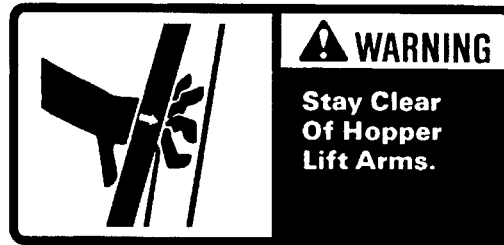

Part Number 301732

Located on the Shroud of the Radiator:



Part Number 301733



# BASIC PowerBoss® SAFETY

PowerBoss® sweepers should never be operated unless: 1. The operator is trained and authorized to operate the equipment and, 2. The equipment is free of malfunctions. Malfunctioning equipment should be removed from service.



- 1. Keep cigarettes, matches and all other flame sources away from the sweeper. Gasoline, LP gas and diesel fuel are highly flammable. Lead acid batteries are equally dangerous due to the highly explosive hydrogen gas they emit.***



- 1. Before starting the engine, make sure that:***
  - \* You are securely seated in the operator's seat.***
  - \* The parking brake is locked.***
  - \* The directional control pedal is in neutral.***
  - \* The throttle is in idle.***
  - \* Hydraulic controls are in the OFF position.***
- 2. During operation:***
  - \* Keep your hands and body clear of moving parts, especially when the hopper or lift arms are partially or fully raised.***
  - \* Make sure others in the area stay clear of the equipment and moving parts.***
  - \* Never attempt to dump debris from a dock or mezzanine. Dump from ground level only.***
- 3. When leaving the sweeper unattended:***
  - \* Place the controls in the OFF position.***
  - \* Set the parking brake.***
  - \* Shut off the engine.***

# BASIC PowerBoss® SAFETY (Continued)

4. ***During cleaning and maintenance:***
  - \* ***Always stop the engine and set the parking brake before servicing.***
  - \* ***Never use detergents or cleansers that are flammable or combustible.***
  - \* ***Never inflate a pneumatic tire without using a safety cage.***
  - \* ***Do not attempt any impeller adjustment unless you have shut off the engine. Never place your hands near the intake hoses or inlet when the engine is running.***
  - \* ***Always engage the safety arm before servicing the hopper. Do not rely on the hydraulic cylinder to keep the hopper raised.***
  - \* ***Never test for hydraulic hose leaks using your hand or any other part of your body. High pressure leaks can be very dangerous and should only be checked using a piece of paper.***
  
5. ***When servicing or repairing the fuel system:***
  - \* ***Work in a properly ventilated area, do not smoke or allow an open flame near the fuel system.***
  - \* ***Never bypass safety components unless you are testing them.***
  - \* ***Never bypass the fuel filter lock, except when testing them (and always reconnect them after testing).***
  - \* ***Wear gloves to disconnect the tank coupling.***
  
6. ***Do not operate an LPG powered sweeper when any component in the fuel system is malfunctioning or leaking.***
  
7. ***Replace any defective safety components before operating the sweeper.***
  
1. ***Do not drive with the hopper in the raised position except the few feet necessary to position the hopper over the dumpster or receptacle. Driving with the hopper raised reduces visibility and creates conditions for striking overhead objects, throwing the machine off-balance and other hazards.***



# BASIC PowerBoss® SAFETY (Continued)

2. *Travel slowly on grades.*
3. *Place a block or chock behind the wheels when parking on inclines.*
4. *Use special care when traveling on wet surfaces.*
5. *Observe all proper procedures for operation and maintenance of the sweeper, as outlined in this manual.*
6. *Remain alert at all times to people and equipment in and around your area of operation.*



1. *Do not operate the #2 RTR lever before the #1 light illuminates.*
2. *Never push or tow a machine faster than 6 mph. If towing the machine is required, you must first disengage the drive wheel by turning the Tow Pin Valve 90°. The Tow Pin Valve is located on the Main Hydraulic Pump attached to the engine. Failure to disengage could result in costly damage to the drive system.*

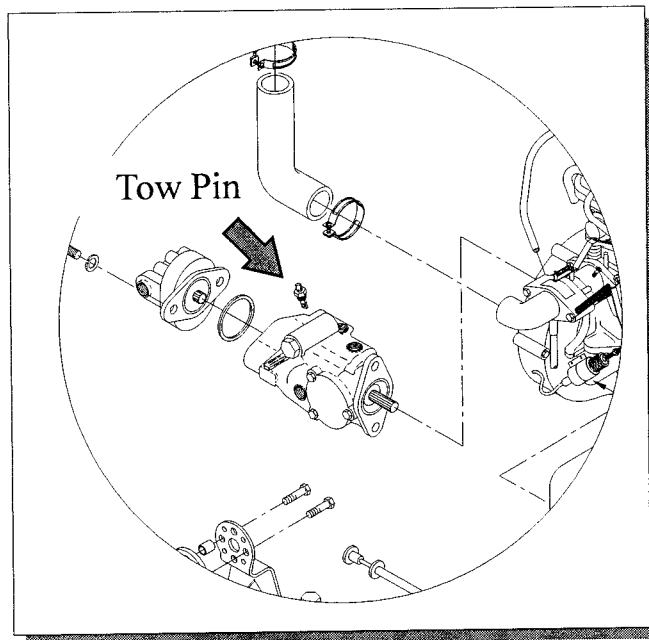

# BASIC OPERATING CONTROLS

## STARTER

To start gasoline powered machines, turn the key to **ON** position and then to the **START** button. To stop the engine, turn the key to **OFF**.

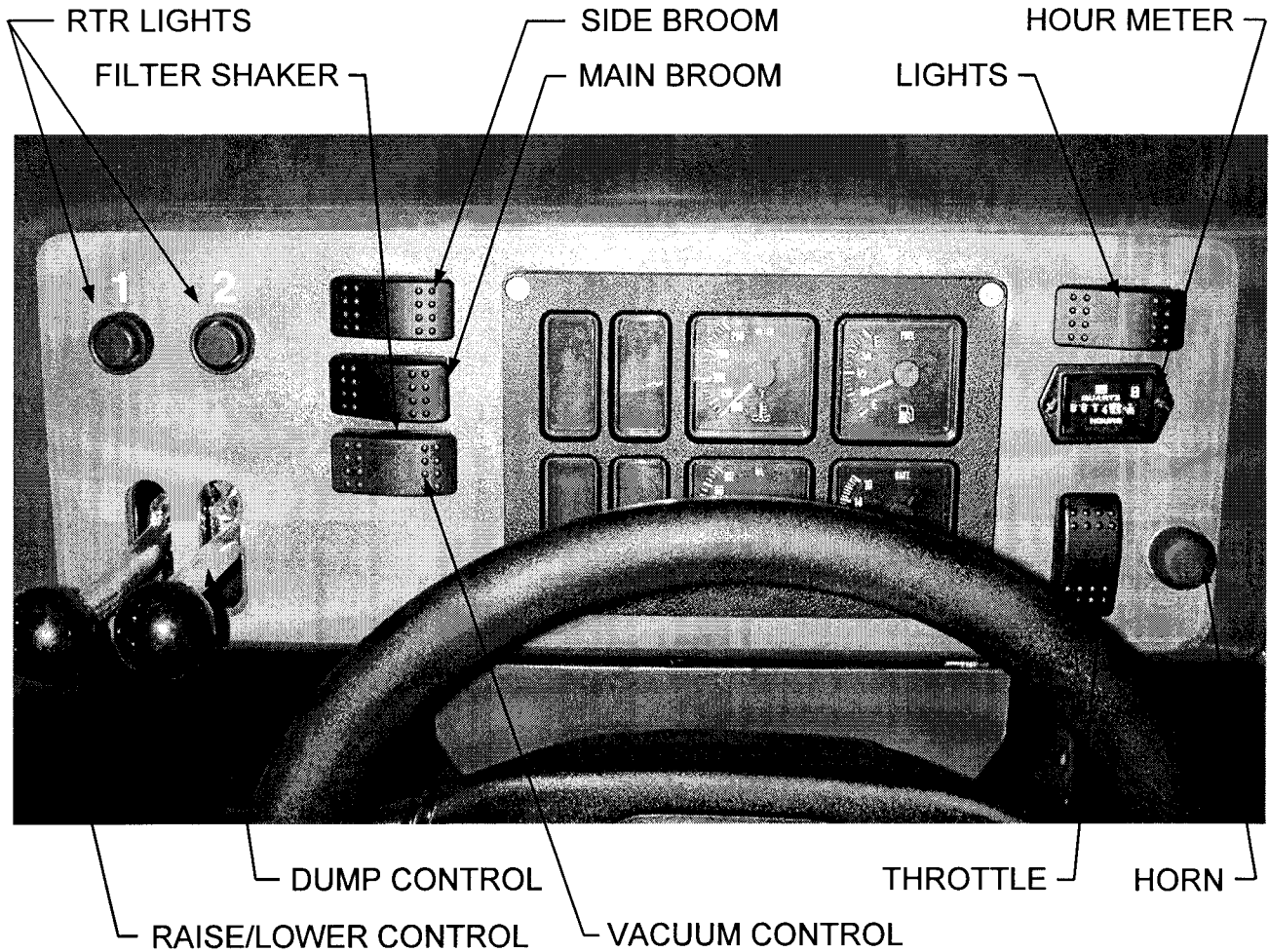

ENGINE COOLANT  
TEMPERATURE

ENGINE OIL  
PRESSURE

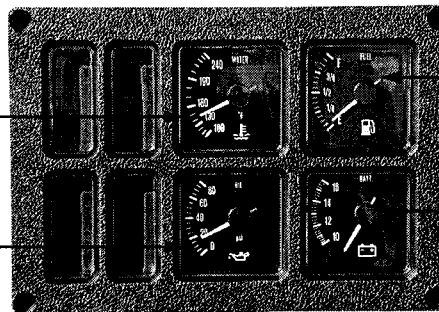

FUEL  
LEVEL

AMMETER

# OPERATING PROCEDURES

## PRE-OPERATION CHECKS

Prior to starting the engine, check the following:

1. Engine oil level
2. Engine coolant level
3. Fuel level
4. Hydraulic fluid level
5. Brakes, steering and directional controls
6. The floor beneath the machine for signs of fluid leaks

Fluid levels should be correct. Brakes, steering and directional controls should be functioning properly. Hoses, lines and tanks should be free of damage and leaks.

## STARTING



***Before starting the engine, sit in the operator's seat and make sure the parking brake is locked.***

1. Make sure the directional control pedal is in the neutral position.
2. Make sure the throttle is in the idle position.  
Turn the ignition key to **START** position.  
When the engine starts, release the key.



***If the engine fails to start, do not continue cranking for more than ten seconds. Allow the starter motor to cool between attempts.***

4. Move the machine forward or backward as follows:
  - **Forward:** Apply pressure to the front of the directional control pedal, increasing pressure to increase speed.
  - **Reverse:** Apply pressure to the rear of the pedal, increasing pressure to increase speed.

## SLOWING AND STOPPING

Allow the directional control pedal to move into neutral. The machine will slow and coast to a stop.

## OPERATING ON GRADES

1. Always travel slowly.
2. Exercise extreme caution when traveling across or turning on grades

## SWEEPING

1. Raise / Lower the Brooms
  - \* To activate the Main Broom, press the **Main Broom** switch beside the gauge cluster to **ON**.
  - \* To activate the Side Broom, press the **Side Broom** switch beside the gauge cluster to **ON**.
2. Drive the machine over the area to be swept.

## EMPTYING THE HOPPER

1. Drive the machine to the dumping area.
2. Use the directional control pedal to position the machine so that the space between the machine and the container or dumpster is adequate to raise the hopper.

### NOTE

**NOTE: Broom and dust control fan will automatically shut off when the hopper is raised.**

3. Position the hopper high enough to clear the top of the container.

### WARNING

***Never place your hands or other body parts near the lift arms when the hopper is operating.***

4. Move the machine forward until the hopper is properly positioned to dump debris into the container.

**⚠ WARNING**

***It is unsafe to travel an extended distance with the hopper raised. Travel only the distance necessary to position the hopper.***

5. Shake the filters for 20-30 seconds. Rotate the hopper forward and empty the debris.
6. After the hopper empties, rotate to the **RETURN** position.
7. Slowly back the machine away from the dumpster approximately 5 feet.
8. Lower the hopper to the bottom position.

**USING THE  
ROTARY TRASH  
RELOCATOR  
(RTR™)**

**NOTE**

**As you complete Steps Two and Three, observe the two red lights labeled 1 and 2 in the upper left corner on the lintel.**

- Light 1 illuminates when the hopper reaches the minimum height required to use the RTR™ feature.
  - Light 2 illuminates when the hopper reaches the rotation stop point.
2. Pull hydraulic lever 1 to raise the hopper until Light 1 illuminates.

**⚠ WARNING**

***Make sure no one is in the area under or around the hopper.***

3. Stroke hydraulic lever 2 to rotate the hopper until Light 2 illuminates.

**NOTE**

**This rotates the hopper, causing debris to move from the rear entrance to the front wall of the hopper. Rotating beyond this point will cause debris to be dumped from the hopper.**

4. Rotate the hopper to the BACK position. (Lever 2)
5. LOWER the hopper to the normal operating position. (Lever 1)

**TRANSPORTING  
THE MACHINE  
Loading**

1. Position the machine on the transport vehicle or trailer and apply the parking brake.
2. Chain the machine down using the tie-down holes in the frame in front of both front wheels and in the rear of the frame. (There is a total of 4 tie-down areas.)

**NOTE**

**NOTE: Attach the tie downs to the frame only.**

**Pushing**

1. Push the machine from the rear using bumpers only.
2. Before towing, open the Tow Valve located on top of the main hydraulic pump by rotating the valve stem 90°. After towing is complete, return the valve stem to its original position. (See picture on page 14)



**PowerBoss®**



***“The Power of Clean”***

PowerBoss, Inc 175 Anderson Street P.O. Box 1227- Aberdeen North Carolina 28315

Phone: 800-982-7141 - Fax: 1-800-277-7141 Local: 910-944-2105 Fax: 910-944-7409 e-mail: [techsupport@powerboss.com](mailto:techsupport@powerboss.com)